

# PRODUCT MANUAL.

## 1200 S 24

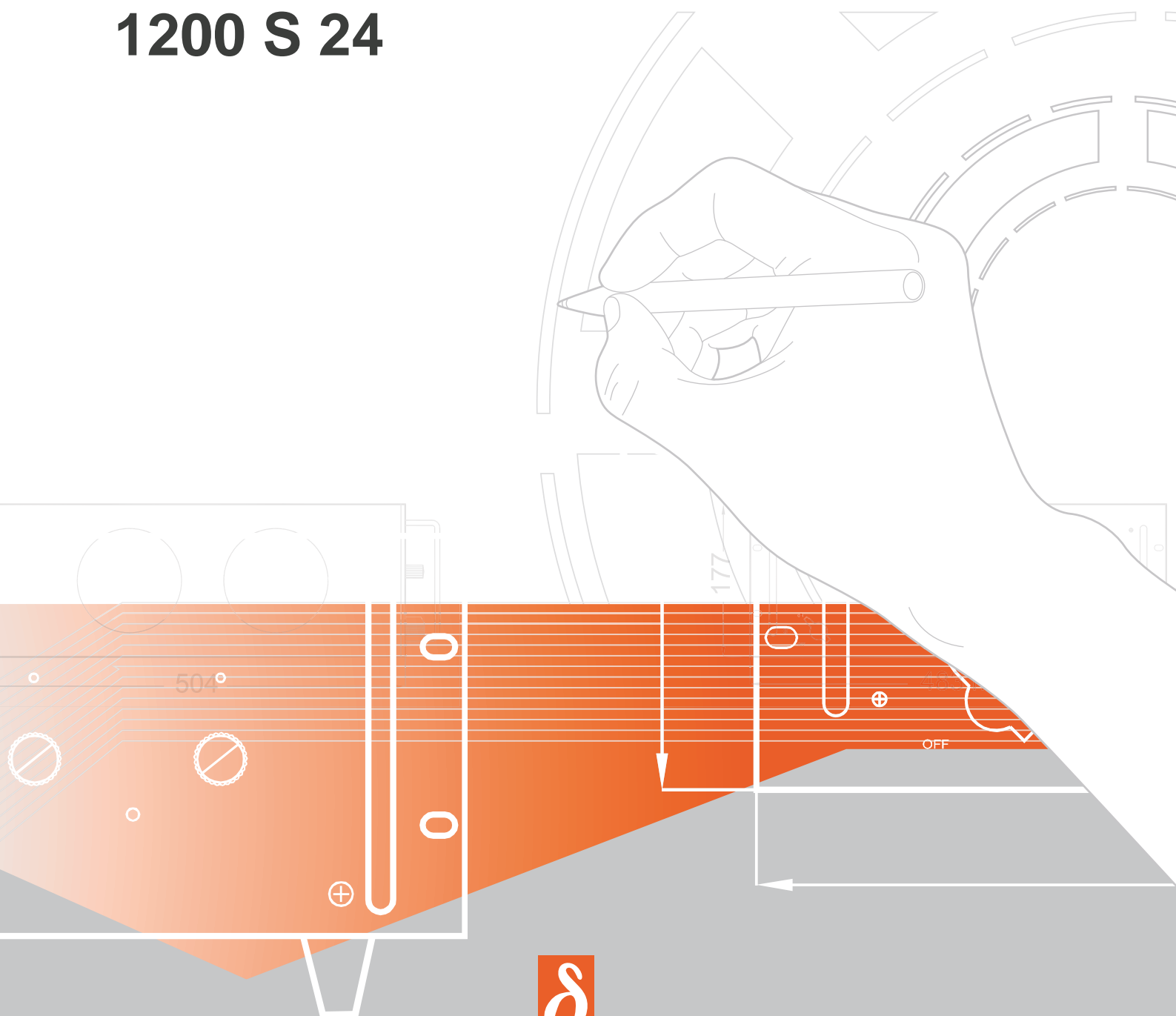

**DELTAELEKTRONIKA**

DC POWER SUPPLIES

# Safety Instructions

## Caution

The following safety precautions must be observed during all phases of operation, service and repair of this equipment. Failure to comply with the safety precautions or warnings in this document violates safety standards of design, manufacture and intended use of this equipment and may impair the built-in protections within.

Delta Elektronika shall not be liable for user's failure to comply with these requirements.

## Installation Category

The Delta Elektronika power supplies have been evaluated to installation category II.(Over voltage category II)

## Grounding of Mains Input

This product is a safety Class 1 instrument. To minimize shock hazard, the instrument chassis must be connected to the AC Power Supply mains through a three or four conductor power cable for resp. a single or three phase unit, with the ground wire firmly connected to an electrical ground (safety ground) at the power outlet.

For instruments designed to be hard-wired to supply mains, the protective earth terminal must be connected to the safety electrical ground before another connection is made. Any interruption of the protective ground conductor, or disconnection of the protective earth terminal will cause a potential shock hazard that might cause personal injury.

## Grounding of Power Output

If the output of a unit is specified to deliver max 60Vdc, and either the negative or positive power output is grounded, the voltage on the following connections can be considered safe:

- power outputs and sense connections
- programming/monitor/status-signals, Interlock, Master/Slave-connections, ACF/DCF-relay
- all Delta Elektronika interfaces.

**Warning:**

When the positive power output can exceed 60Vdc in respect to the negative output, additional external measures must be taken to ensure safety isolation of the following:

- power outputs and sense connections.

**Warning:**

When the negative power output of the unit can exceed 60Vdc / 42.4Vpk in respect to ground, additional external measures must be taken to ensure safety isolation of the following:

- power outputs and sense connections
- programming/monitor/status-signals, Interlock, Master/Slave-connections, ACF/DCF-relay
- interfaces with operational isolation

**Caution 1:** If a low voltage unit has both power outputs floating, or if the output is in series with an external high AC or DC voltage, the negative power output can exceed the safe value in respect to ground as specified in the above warning!

**Caution 2:** Although a high voltage unit is set to a safe voltage below 60V, for safety it must always be considered as high voltage unit! Wrong operation, a programming error or an external defect can result in an unsafe high output voltage.

**Caution 3:** When programming a high voltage unit directly via a PC or via a network connection, either ground the negative power output or use a safety isolated interface!

For more information and schematics regards Grounding and Safety, see the special application note "Safe operation of a power supply" on the Delta Elektronika website.

## Fuses

Fuses must be changed by authorized Delta Elektronika service personnel only, for continued protection against risk of fire.

## Input Ratings

Do not use an AC Supply which exceeds the input voltage and frequency rating of this instrument. The input voltage and frequency rating of the Delta Elektronika power supply series are stated in the accompanying datasheet.

## Live Circuits

Operating personnel must not remove the instrument cover. No internal adjustment or component replacement is allowed by non Delta Elektronika qualified personnel. Never replace components with the power cable connected. To avoid injuries, always disconnect power, discharge circuits and remove external voltage sources before touching components.

## Parts Substitutions & Modifications

Parts substitutions and modifications are allowed by authorized Delta Elektronika service personnel only. For repairs or modifications the unit must be returned to a Delta Elektronika service facility.

## Removal of (safety) covers

Safety cover(s) are used to cover potentially hazardous voltages.

Observe the following when removing safety cover(s):

- Switch off the unit.
- Disconnect the unit from the mains supply.
- Wait for 3 minutes to allow internal capacitors to discharge.
- Unscrew the screws and remove the cover(s).
- Always place the cover(s) back before connecting the unit to the mains supply again.

## Environmental Conditions

The Delta Elektronika power supplies safety approval applies to the following operating conditions:

Indoor use

Ambient temperature : -20 to 50 °C

Maximum relative humidity : 95%, non condensing, up to 40 °C

: 75%, non condensing, up to 50 °C

Altitude: up to 2000 m

Pollution degree 2



*Caution risk of electrical Shock*



*Instruction manual symbol. The instrument will be marked with this symbol when it is necessary for the user to refer to the instruction manual*



*Protective ground conductor terminal*



*Off (supply)*



*On (Supply)*

## WEEE

### (Waste Electrical & Electronic Equipment)

### Correct Disposal of this Product

Applicable in the European Union.



This marking shown on the product, its packing or its literature indicates that it should not be disposed with other wastes at the end of its working life, but should be collected separately to recycle it responsibly to promote the sustainable reuse of material resources.

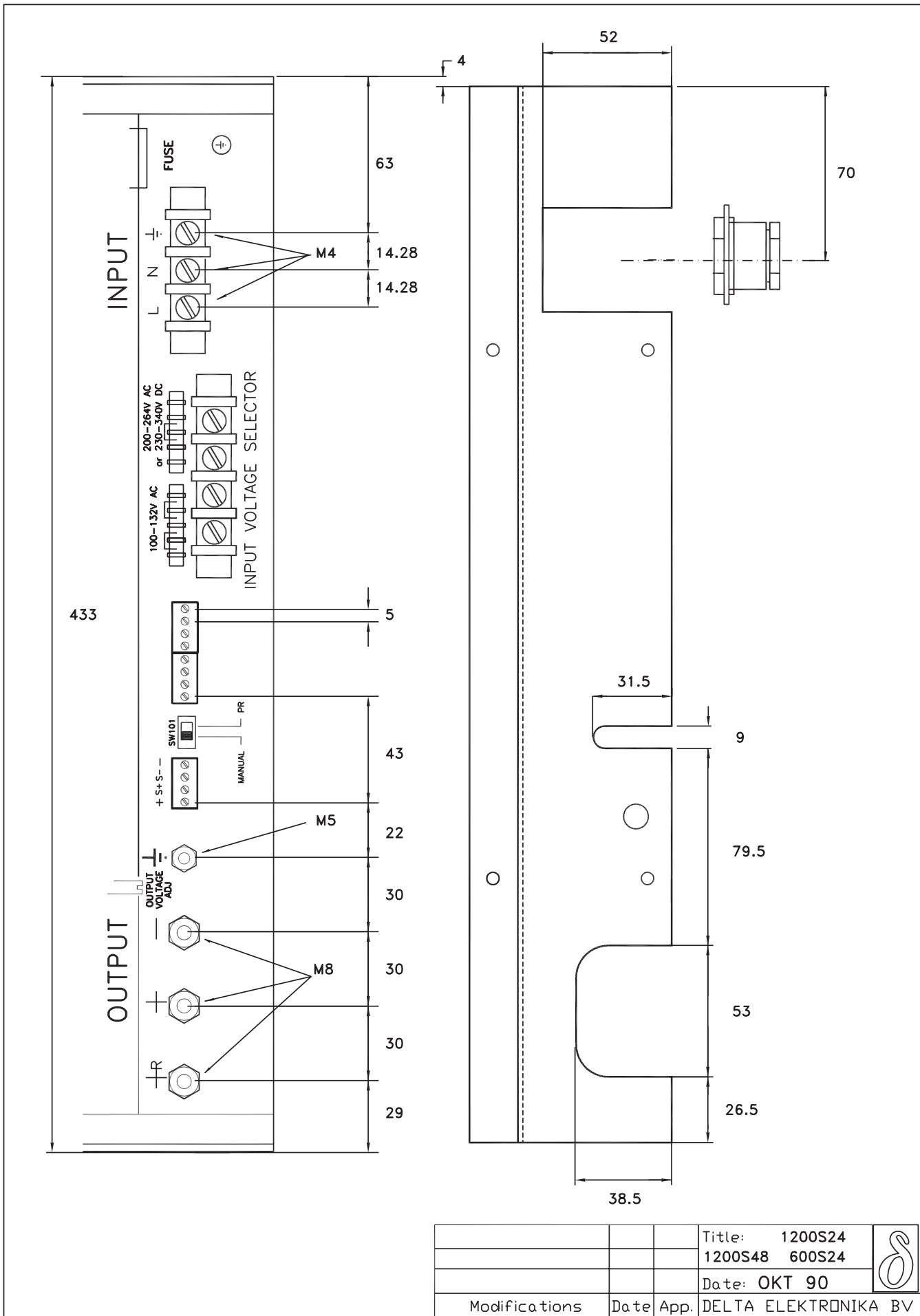

## Warning

Before opening the enclosure disconnect the unit from the line voltage and wait three minutes to give the electrolytic capacitors time to discharge.

Also be careful with the low voltage high current output because it can cause harm when a ring or wrist watch, attached to a person, shorts the output terminals. Also a high current can vaporize metallic objects such as screwdrivers and the molten metal can be sprayed on people.

## Installation and operation

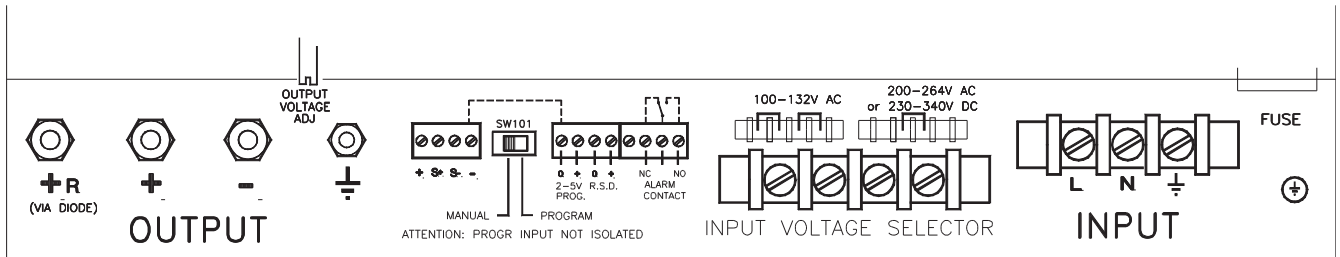

### Input voltage selector

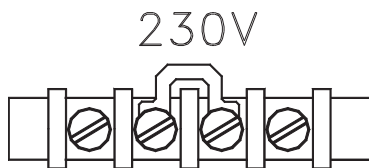

The power supply has a wide input voltage range. With the jumper in the 230 V position it can be used at any line voltage between 200 and 264 V AC 48/62 Hz or 230 and 340 V DC. Put fuse 15 A in fuse holder.

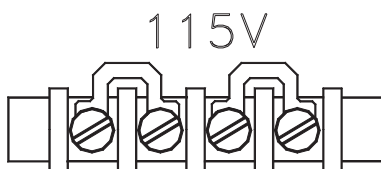

With the two jumpers in the 115 V position it can be used at any line voltage between 100 and 132 V AC 48/62 Hz. A DC input cannot be used with the jumpers in this position since the input circuit is connected as a voltage doubler. Put fuse 25 A in fuse holder.

### Sense block



For normal operation S+ has to be connected to + and S- to -.

### Recommended wire

Model	INPUT		OUTPUT	
	230 V AC	115 V AC		Voltage drop
1200S24	2.5 mm <sup>2</sup>	4.0 mm <sup>2</sup>	16 mm <sup>2</sup>	56 mV/m at 50 A
1200S48	2.5 mm <sup>2</sup>	4.0 mm <sup>2</sup>	6 mm <sup>2</sup>	75 mV/m at 25 A

## Inrush current

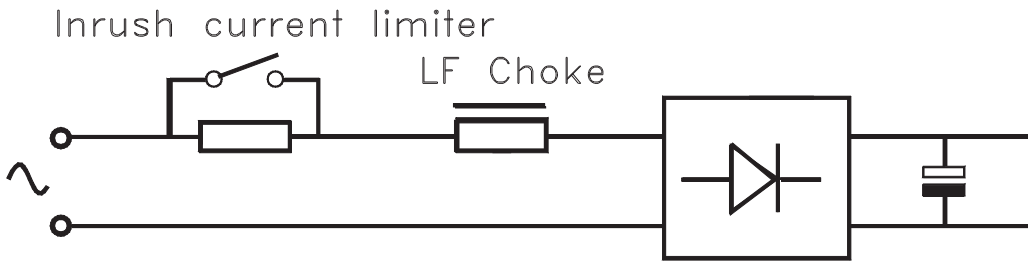

The inrush current limiter limits the inrush current to less than 40 A during 5 milliseconds. At turn on the electrolytic capacitors charge through a PTC series resistor of about 40 Ohms. When they are charged sufficiently the series resistor is shorted by a heavy relay contact and the power supply starts operating. In case of a relay failure the PTC becomes high ohmic and limits the current to a safe value.

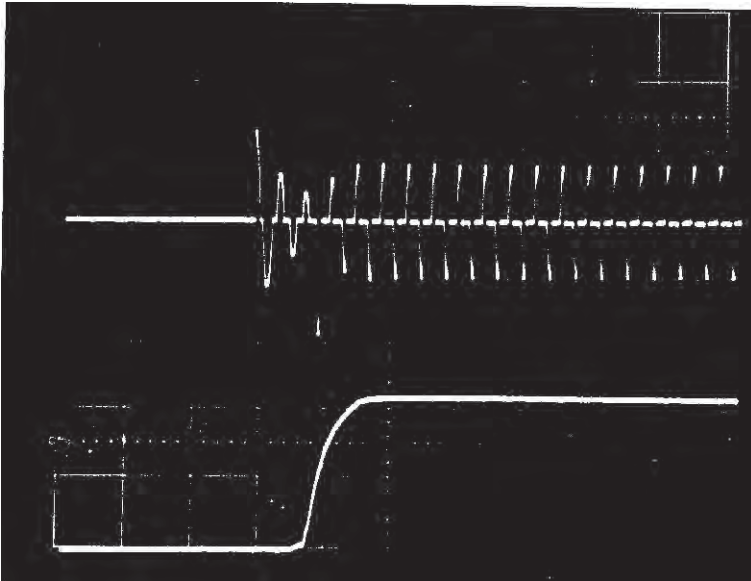

1200S24

Input current, vert. 20 A/div., hor. 50 mS/div.

Output voltage, vert. 10 V/div., hor. 50 mS/div.

## Input choke (passive power factor correction)

A switched mode power supply with a bridge rectifier and an electrolytic capacitor at the input takes current only in the peaks of the sine waves. These narrow current peaks can cause distortion in the line voltage.

To minimize this distortion the 1200S has a large low frequency choke with an airgap in series with the input. Such an LF choke is usually not found in power supplies of other manufacturers.

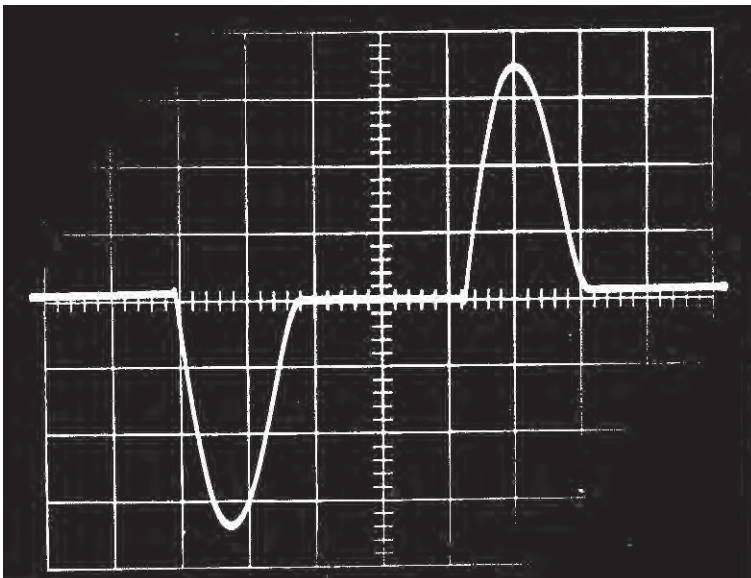

1200S24

Input current at 1200 watts load

Vertical scale: 5 A/div.  
Horizontal scale: 2 mS/div.

## Vertical mounting

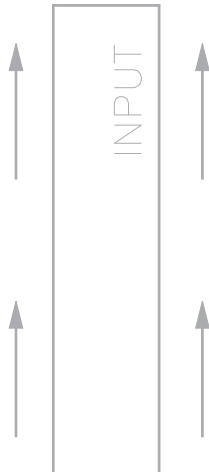

For convection cooling the ideal way of mounting is vertically. For the best internal heat distribution it is recommended to keep the input block at the upper side.

The power supply is so constructed that the heat generated in the semiconductors and transformer flows through a thick aluminium

profile to both covers which act as heat sinks. So it is important that the air can flow freely vertically along both sides. This design with natural convection cooling was chosen to avoid the use of a blower which has disadvantages like noise, dust filters, wear and tear.

At 1200 W output and 89% efficiency the total heat dissipation is  $1200 \text{ W} / 0.89 - 1200 \text{ W} = 148 \text{ watts}$ .

For vertical mounting two types of brackets are available H88 and H114.

## Horizontal mounting

Horizontal mounting is also possible, on the condition that the max. ambient temperature does not exceed 40 °C at full load (instead 50 °C when mounted vertically). The current limit switch can be put on 'LO' to limit the max. output to 1100 W.

When used in a 19" rack keep sufficient space around the unit for cooling. If more power supplies are mounted above each other the use of forced air to cool is recommended.

For 19" rack mounting brackets H88 with a handle are available.

## Remote sensing



For most applications remote sensing is not necessary. However, if the voltage at the load has to be kept very constant (within millivolts) and the voltage drop across the load leads is large, remote sensing is useful. With remote sensing the voltage is kept constant across the load instead of at the output terminals of the power supply.

The maximum sense range per load lead is 3V. However the voltage across the output terminals, which is the sum of the voltage across load plus leads, cannot exceed 30 V (60 V 1200S48). The two load leads have to be kept closely parallel to minimize the inductance. If there is a capacitor at the load it can together with the lead inductance cause oscillations.

This can be stopped by an electrolytic capacitor of 12000  $\mu\text{F}$  at the load. Also the sense leads have to be kept close together to minimize pick up of noise.



## Parallel operation

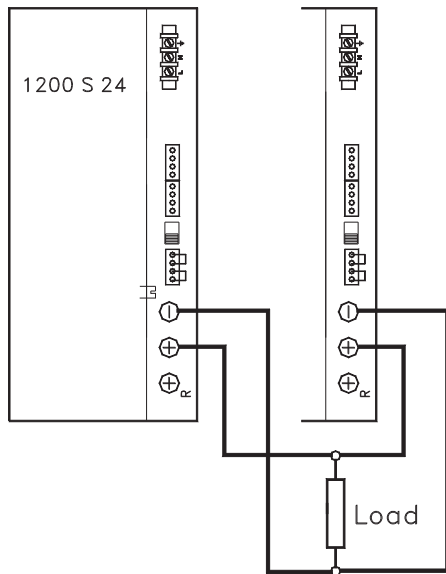

To obtain higher current two or more units can be used in parallel. Before connecting them in parallel first adjust each output to the same voltage. The current limit switch of the 1200S models has to be put on 'LO' to limit the maximum output per unit to about 1100 watts.

## Redundant parallel operation

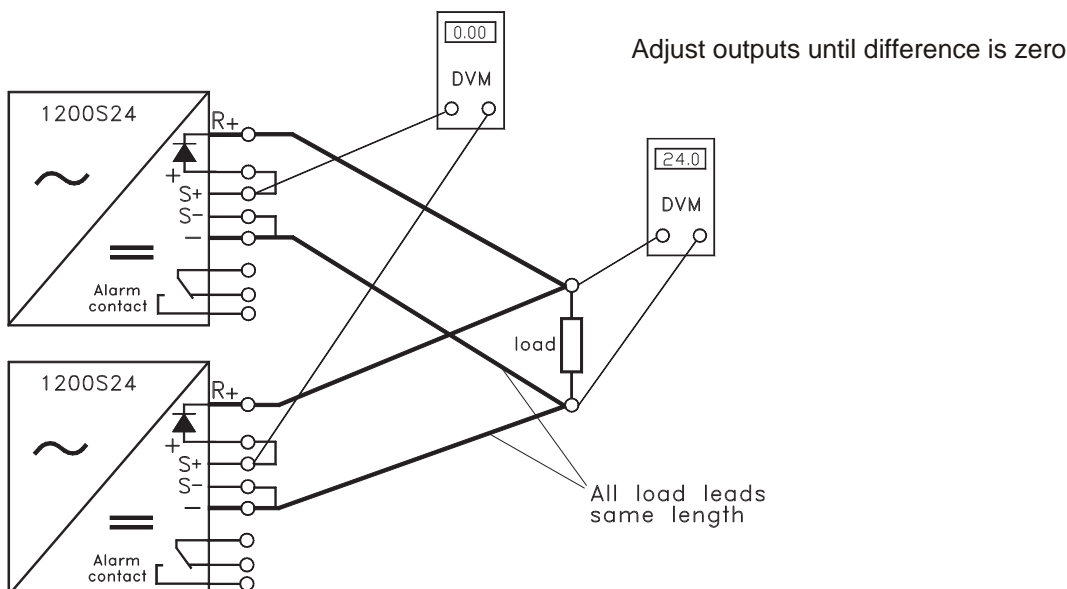

For redundant operation the 1200S units have a built in series diode and an undervoltage alarm contact. This contact can be used as normally open or as normally closed.

The current limit of the 1200S24 and 1200S48 is factory adjusted slightly above 100%. For parallel operation the current limit can be reduced to about 90% by putting the current limit switch at the front panel at low.

To get a reasonable current sharing the output voltages of the two or more units have to be adjusted to the same voltage.

An easy way is to measure the voltage difference at a low range of a multimeter and adjust this to zero. After careful adjustment the current sharing is usually within 10%.

It is also important that all the load leads to the summing points have the same resistance (same length).

### Parallel operation with external voltage control with one potentiometer

The output voltage of two or more units can be controlled by one external potentiometer. Before connecting them in parallel first calibrate the programming input sensitivity of each power supply. Put 5V from an external source at the progr. input and turn the internal voltage control potentiometer until the output voltage is 30 V. After this calibration the power supplies can be connected as drawn. The link between S- and - has to be removed from all units. Do not remove the link between S+ and +. Many units can be operated in parallel to be used as one big power supply.

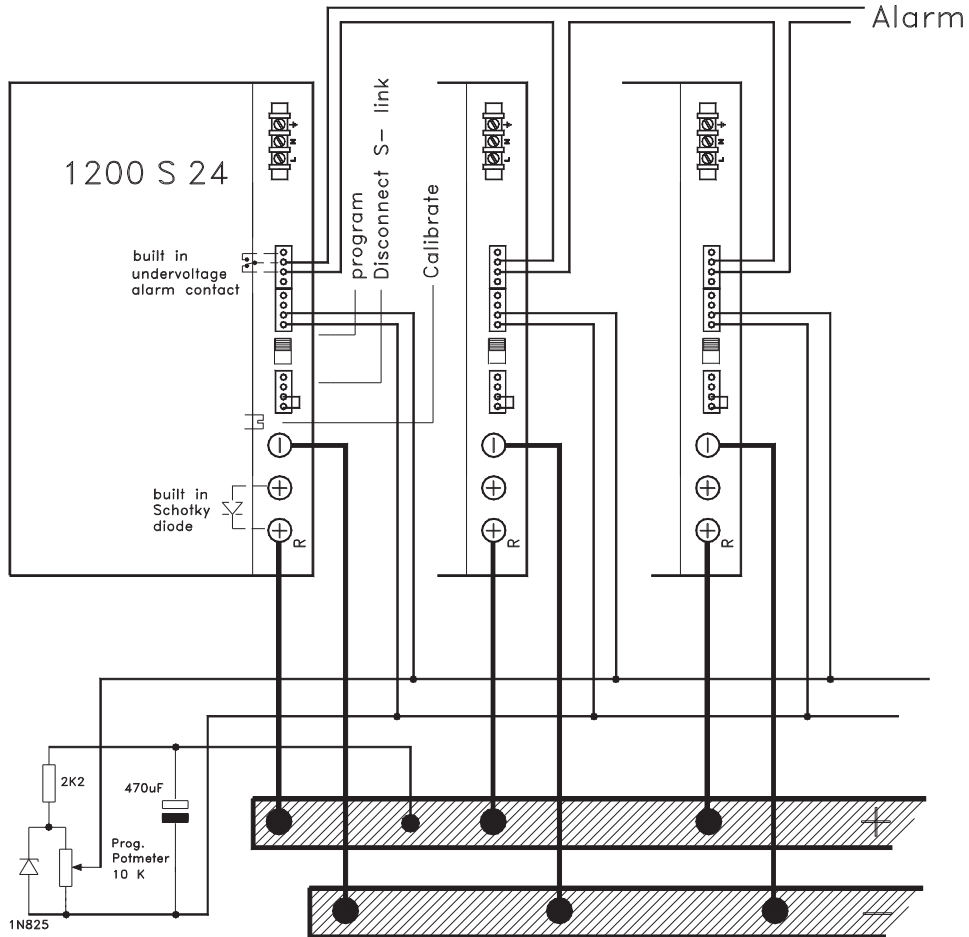

### Remote voltage control

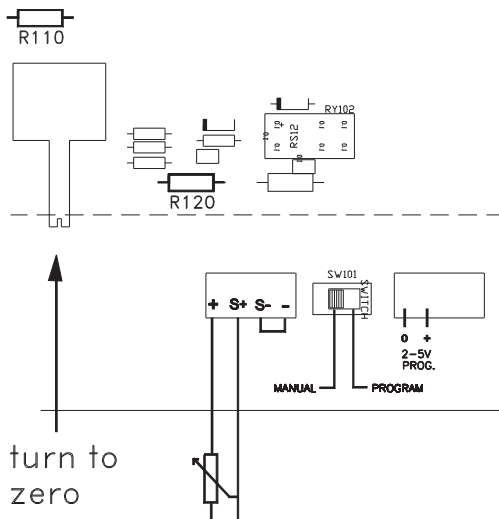

Voltage adjustment with an external potentiometer of 10 kOhms is possible if R 120 and R 110 are removed. The potentiometer can be connected as a variable resistor between S+ and + at the sense block. The internal potmeter has to be turned to zero.

This method of voltage control by external potentiometer cannot be used with parallel operation.

## Remote programming

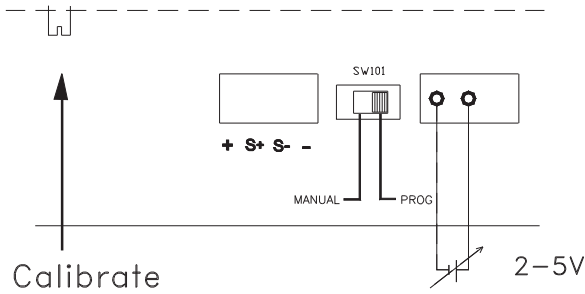

Attention: The programming input is not isolated. The zero of the progr. input is connected to minus output. When the small switch near the programming input is put on PROG (program) the output voltage of the power supply can be programmed by an analog voltage of 2 to 5V, corresponding with 12 to 30 V output. For 1200S48 this is 24 to 60 V . The programming speed is 100 milliseconds for a change from 12 to 30 V at full load. The programming range 2-5 V can be calibrated with the 10-turn voltage adjustment potentiometer. To calibrate put 5V at the programming input and turn the voltage adjustment potentiometer till the output voltage is 30 V (60 V).

1200S24

Output 12 - 30 V 40 A  
 Vert.: 5V / div.  
 Hor.: 20 mS / div.

Programming voltage 2 - 5 V  
 Vert.: 2 V / div.  
 Hor.: 20 mS / div.

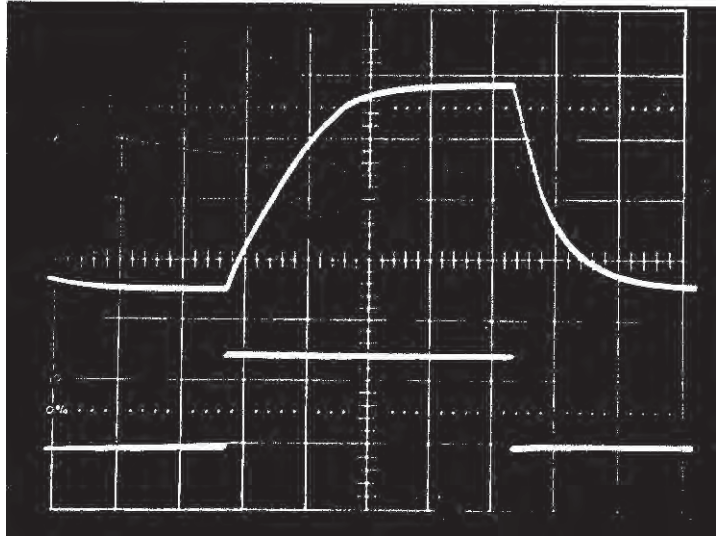

## Remote ShutDown

Remote ShutDown of the output voltage is possible by 5V (3-12 V) at the RSD input. The RSD input is low ohmic (500 Ω). The RSD input is isolated from the output by an optocoupler (isolation 1000 V).

Programming

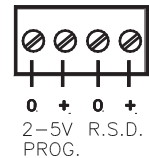

## Current limit

The current limit is fixed and has a more or less constant power characteristic. The 1200S models have a switch, accessible through a hole in the front panel, which can be put on HI or LO by a screw driver. On LO the maximum output power is limited to about 1100 watts.

## Insulation

For safety, the insulation of the separating components (transformers and optocouplers) between input and output are tested at 3750 Vrms during 1 minute. This is tested before assembling. The 3750 Vrms cannot be tested afterwards on the assembled unit because the insulation between the components on the input side to the case (like the bridge rectifier) is specified at 2500 Vrms. Since the insulation output - case is low (only 500 V DC) the insulation of the primary components to case will break down when 3750 Vrms is applied between input and output (2500 Vrms + 500 V DC < 3750 Vrms). The Y-capacitors of the RFI filter make it difficult to test with 2500 V AC between input and case. It is more practical to test with 1.4 x 2500 = 3500 V DC.

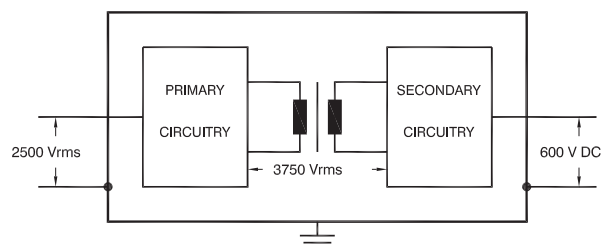

### Dividing the load in sections, each with its own fuse

In general it is not recommended to use a fuse in the DC output of an electronic regulated power supply. The electronic current limit is very fast compared to fuses and it is sharply defined so there is not enough time and not enough over current to blow a fuse.

This makes it difficult to divide the load in sections each with its own fuse.

Even for very fast fuses the time to blow is still in the order of 50 seconds at twice the nominal current ( $2 I_N$ ). At  $4 I_N$  this is already much better and can be in the order of 20 milliseconds.

However compared with the electronic current limit this is still too long and all sections will see a dip in the 24 V. The best results we found with the circuit breakers S 280 Z of ABB. They are the fastest.

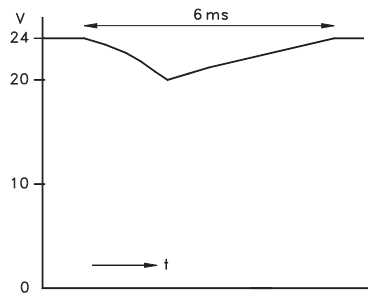
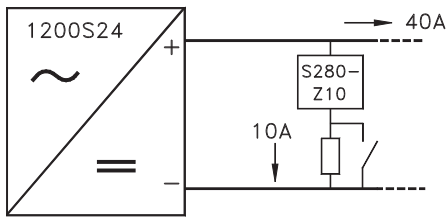
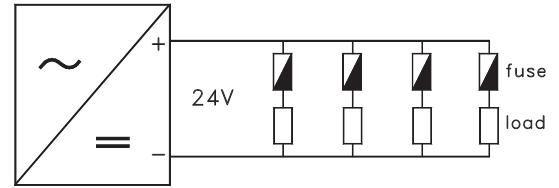

In the above situation there is still a considerable voltage dip during 6 ms. This can be improved by one or more large electrolytic capacitors which can supply a high current peak for a fast action of a fuse or a circuit breaker.

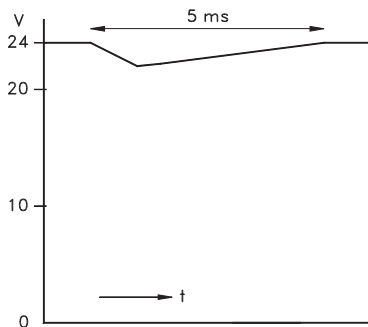
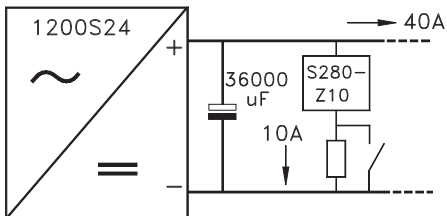

1200S24 with 36 000  $\mu F$  parallel

A disadvantage of the large electrolytic capacitor can be that the current limit is no longer fast.

The inductance of long leads (several meters) between the power supply and the load can cause very large voltage dips when a fuse is blown. This can be avoided by connecting the electrolytic capacitor close to the load.



## EC Declaration of Conformity

We

Delta Elektronika  
P.O. BOX 27  
4300 AA ZIERIKZEE  
The Netherlands

Declare under sole responsibility that the following Power Supplies:

**1200 S 24**  
**1200 S 48**

Meet the intent of Directives 2004/108/EC for Electromagnetic Compatibility and Directives 2006/95/EC regarding Electrical Safety. (Low Voltage Directive)  
Compliance was demonstrated to the following specification as listed in the official Journal of the European Communities:

**EN 61000-6-3 Generic Emissions:** (residential, light industrial)

EN 55022 Radiated and conducted, Class **B**  
EN 61000-3-2 Power Harmonics <sup>1)</sup>  
EN 61000-3-3 Voltage fluctuation and flicker

**EN 61000-6-1 Generic Immunity:** (residential, light industrial)

**EN 61000-6-2 Generic Immunity:** (industrial environment)

EN 61000-4-2 Electrostatic Discharge  
EN 61000-4-3 Radiated electromagnetic fields  
EN 61000-4-4 Electrical Fast Transients / Bursts  
EN 61000-4-5 Surge immunity  
EN 61000-4-6 RF common mode, conducted  
EN 61000-4-11 Voltage variations and dips

**EN 60950 Safety of IT equipment**

**EN 61010 Safety of electrical equipment for measurement, control and laboratory use**

<sup>1)</sup> This product is intended for professional use and installation. The input power > 1kW.  
Consult the utility company when connecting to the public mains.



**DELTAELEKTRONIKA B.V.**

Delta Elektronika B.V.  
Vissersdijk 4  
4301 ND Zierikzee  
The Netherlands  
Tel. +31 111 413656  
Fax. +31 111 416919

[www.deltapowersupplies.com](http://www.deltapowersupplies.com)

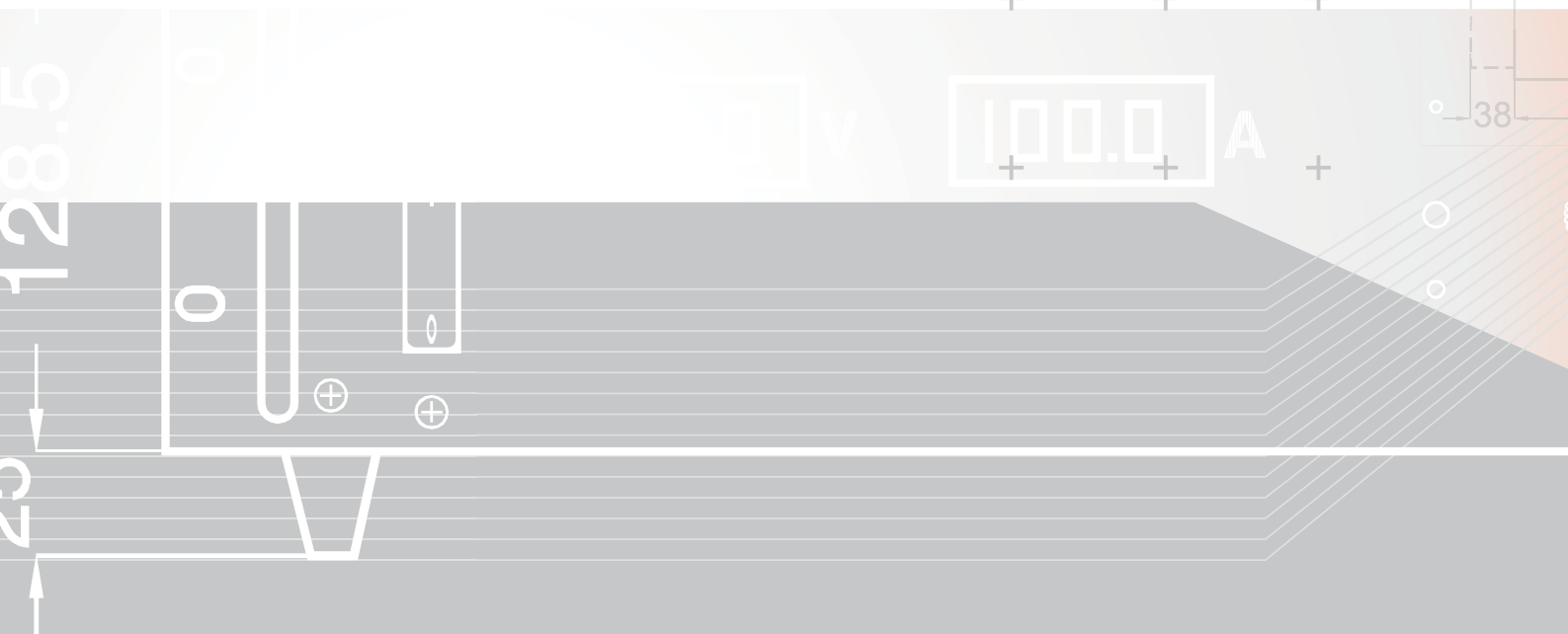

DC POWER SUPPLIES