

# PRODUCT MANUAL.

## 240 S 24

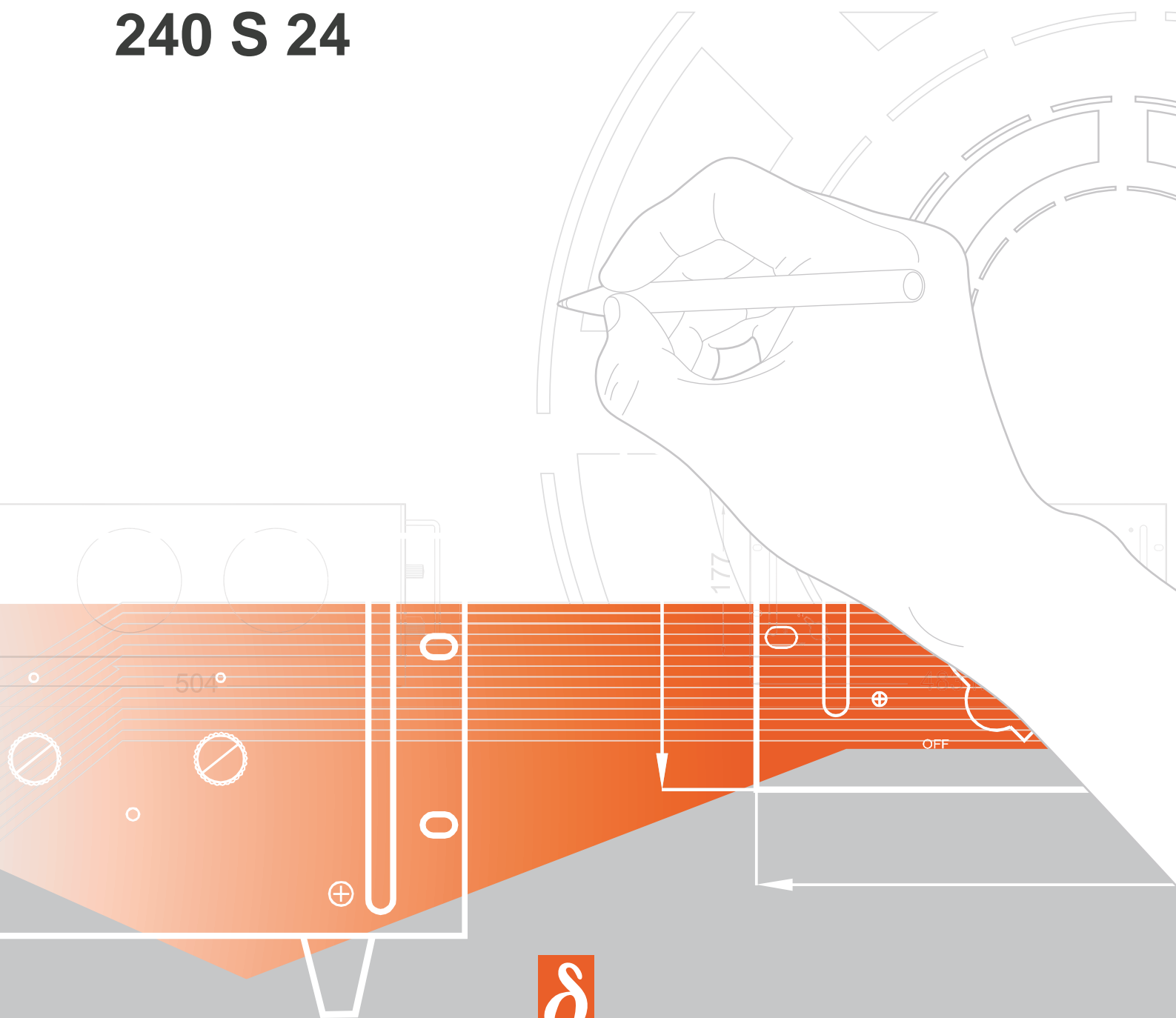

**DELTAELEKTRONIKA**  
DC POWER SUPPLIES

# Safety Instructions

## Caution

The following safety precautions must be observed during all phases of operation, service and repair of this equipment. Failure to comply with the safety precautions or warnings in this document violates safety standards of design, manufacture and intended use of this equipment and may impair the built-in protections within. Delta Elektronika shall not be liable for user's failure to comply with these requirements.

## Installation Category

The Delta Elektronika power supplies have been evaluated to installation category II.(Over voltage category II)

## Grounding

This product is a safety Class 1 instrument. To minimize shock hazard, the instrument chassis must be connected to the AC Power Supply mains through a three or four conductor power cable for resp. a single or three phase unit, with the ground wire firmly connected to an electrical ground (safety ground) at the power outlet.

For instruments designed to be hard-wired to supply mains, the protective earth terminal must be connected to the safety electrical ground before another connection is made. Any interruption of the protective ground conductor, or disconnection of the protective earth terminal will cause a potential shock hazard that might cause personal injury.

## Fuses

Fuses must be changed by authorized Delta Elektronika service personnel only, for continued protection against risk of fire.

## Input Ratings

Do not use an AC Supply which exceeds the input voltage and frequency rating of this instrument. The input voltage and frequency rating of the Delta Elektronika power supply series are stated in the accompanying datasheet.

## Live Circuits

Operating personnel must not remove the instrument cover. No internal adjustment or component replacement is allowed by non Delta Elektronika qualified personnel. Never replace components with the power cable connected. To avoid injuries, always disconnect power, discharge circuits and remove external voltage sources before touching components.

## Parts Substitutions & Modifications

Parts substitutions and modifications are allowed by authorized Delta Elektronika service personnel only. For repairs or modifications the unit must be returned to a Delta Elektronika service facility.

## Removal of (safety) covers

Safety cover(s) are used to cover potentially hazardous voltages.

Observe the following when removing safety cover(s):

- Switch off the unit.
- Disconnect the unit from the mains supply.
- Wait for 3 minutes to allow internal capacitors to discharge.
- Unscrew the screws and remove the cover(s).
- Always place the cover(s) back before connecting the unit to the mains supply again.

## Environmental Conditions

The Delta Elektronika power supplies safety approval applies to the following operating conditions:

Indoor use

Ambient temperature : -20 to 50 °C

Maximum relative humidity : 95%, non condensing, up to 40 °C

: 75%, non condensing, up to 50 °C

Altitude: up to 2000 m

Pollution degree 2



*Caution risk of electrical Shock*



*Instruction manual symbol. The instrument will be marked with this symbol when it is necessary for the user to refer to the instruction manual*



*Protective ground conductor terminal*



*Off (supply)*



*On (Supply)*

## WEEE

### (Waste Electrical & Electronic Equipment)

### Correct Disposal of this Product

Applicable in the European Union.



This marking shown on the product, its packing or its literature indicates that it should not be disposed with other wastes at the end of its working life, but should be collected separately to recycle it responsibly to promote the sustainable reuse of material resources.

## INSTALLATION AND OPERATION

### 1. Euro Cassette

The two supplied brackets can be mounted as slides in order to use the unit as a Euro Cassette which can be plugged into a 19" Card frame for Euro Cards of 6 HE height.

Use as Euro Cassette has the advantage that it can easily be plugged into a card rack.

Also when two units are used in redundant it is possible to exchange a unit during operation in case of emergency.

### 2. Wall mounting

The same two brackets used as slides can be mounted differently (by using other holes) for wall mounting.

Vertical mounting (see drawing p.1-2) is the best position for convection cooling. Always take care to keep some space around the unit so that the air can flow freely vertically along the unit. Keep the connector on the high side as drawn. This is the best for the internal heat distribution.

Horizontal mounting is also possible but with the restriction that the ambient temperature (the air around the unit) does not exceed 40°C.

When forced air cooling is used the unit can be mounted in any position.

A small clamp (CL15) supplied with the unit keeps the H15 mating connector in position in case of wall mounting.

A mating connector H15 with faston tabs is supplied with each unit but mating connectors with screw terminals are also available (see price list).

### 3. Input fuse

The input fuse (fuse-holder at the rear panel) is 4 A slow blow at 230 V AC input and 6.3 A slow blow at 110 V AC input.

At 230 V AC the input current at full load is 1.8 Arms. However at switch-on the inrush current is about 15 A peak during 5 milliseconds which requires a slow blow fuse.

In general the use of fuses in the output of a regulated power supply with electronic current limit is impractical because fuses are much slower than the electronic current limit. Also a fuse needs a very high peak current to blow within a reasonable time and the current limited unit cannot supply this.

### 4. Input

See fig. 3 - 1 and fig. 3 - 2

### 5. Output

Because the sense points (pin 8 and 10) are internally connected with + and - output (pin 6 and 12) there are two pins available for + output and also two pins for - output. To keep the contact resistance as low as possible the two contacts can be used in parallel (see fig. 3 - 3).

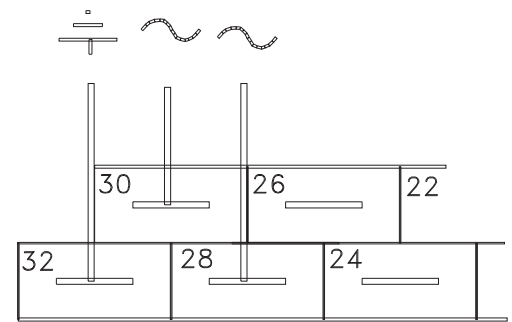

fig. 3 - 1

Input 230 V  
195 - 265 V 48 - 62 Hz

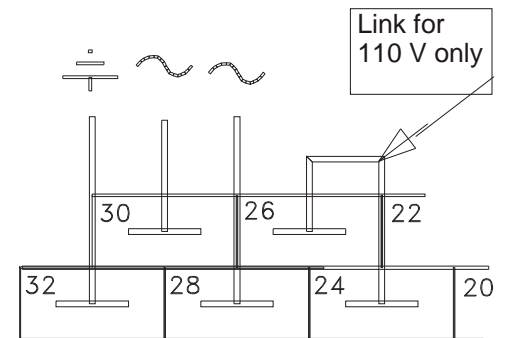

fig. 3 - 2

Input 110 V  
100 - 132 V 48 - 62 Hz

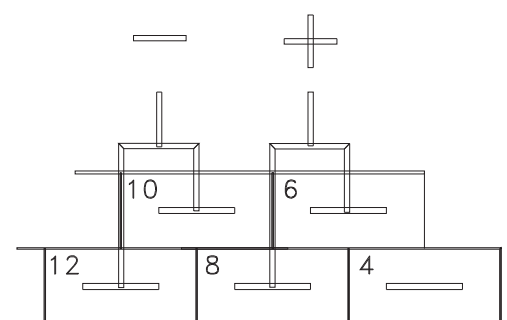

fig. 3 - 3

### 6. Parallel operation

When the power supplies are used in parallel (to double the current) or in redundant operation (to have 100% reserve) terminal 4 (R+) has to be used as plus output (see fig. 3 - 4). In that case an internal diode is connected in series to separate the output circuits. The separation diodes make it possible to see if both units have output and also prevents a failure in one unit to influence the others.

In case of parallel operation the current limit switch SW201 at P401 has to be put on L (=low). This reduces the current limit about 10%. To find this switch the cover has to be removed.

**Warning:** before opening the cover disconnect the input voltage and wait 3 minutes for discharge of the electrolytic capacitors. With some experience the switch SW201 can also be changed with a screwdriver through the holes of the cover (see fig. 3 - 5).

With parallel operation do not use external sensing but put the output 0.5 V higher to compensate for the voltage drop over the (Schottky barrier) diode.

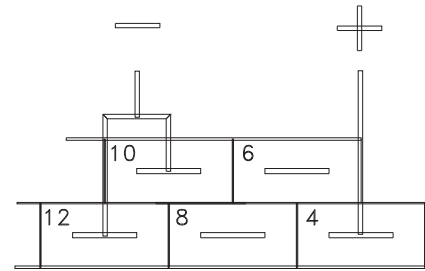

fig. 3 - 4

### 7. Redundant Parallel operation

For redundant operation the 240S24 has a built in series diode and an undervoltage alarm contact (see fig. 3 - 6). The alarm contact is a change over contact, so it can be used normally open or normally closed. The current limit is factory adjusted at about 110%. For parallel operation the current limit can be reduced to about 95% by a little switch SW201 at PCB P401.

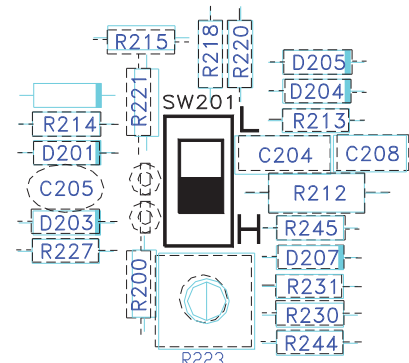

fig. 3 - 5

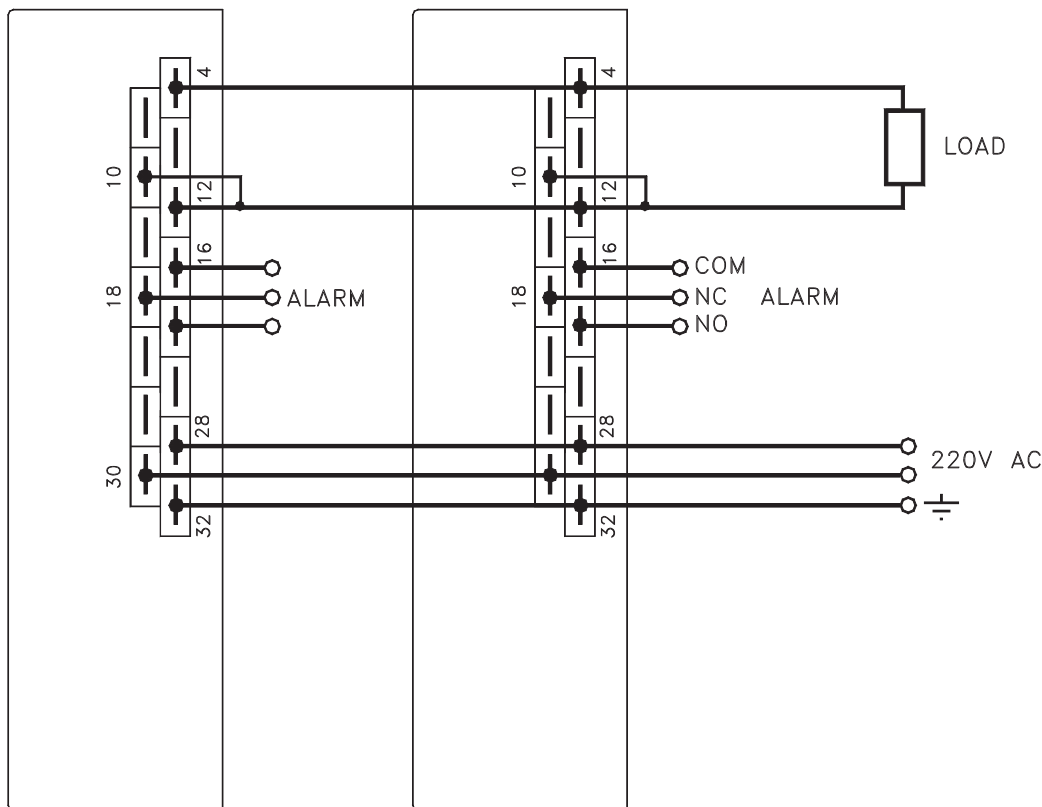

fig. 3 - 6

Redundant parallel operation with undervoltage alarm

To get a reasonable current sharing the output voltages of the two or more units have to be adjusted to the same voltage. An easy way is to measure the voltage difference at a low range of a multi meter and adjust this to zero (fig. 3 - 7).

It is also important that all the load leads to the summing points have the same resistance (same length)

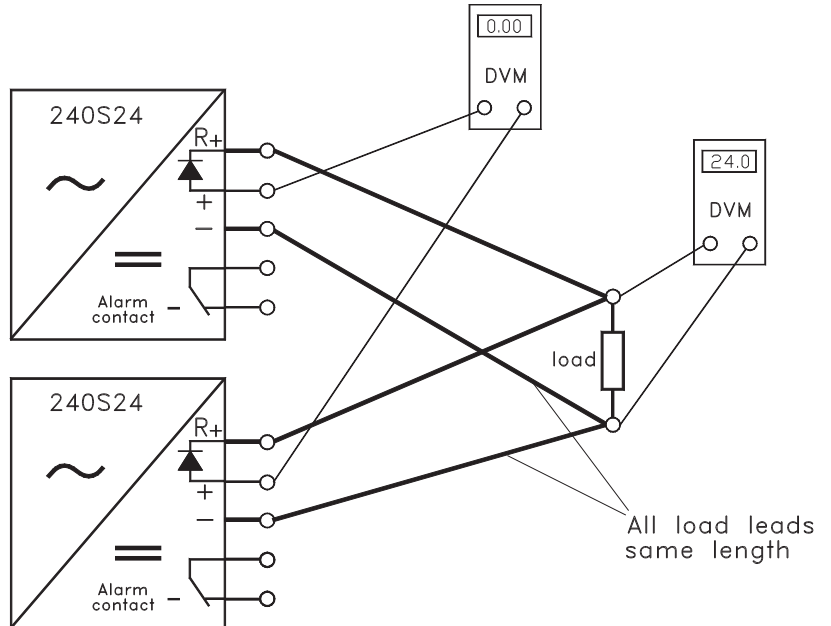

fig. 3 - 7

**8. Low output voltage alarm**

When the output voltage drops about 10% below the set voltage a small relay changes over.

(see fig. 3 - 8)

The relay contacts are isolated from the power supply and connected to pins 16, 18 and 20.

Pin 16 is common.

At normal operation the contact between pin 16 and 18 is closed.

The relay contact is a gold contact with rating 100 mA / 30 V.

**9. Parallel operation with external voltage control**

The voltage of two or more units can be controlled by only one potentiometer (see fig. 3 - 9).

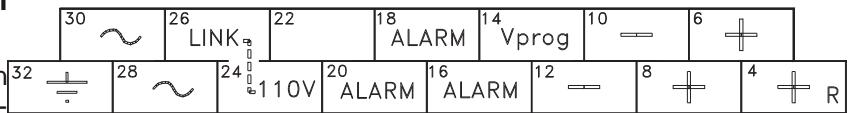

fig. 3 - 8

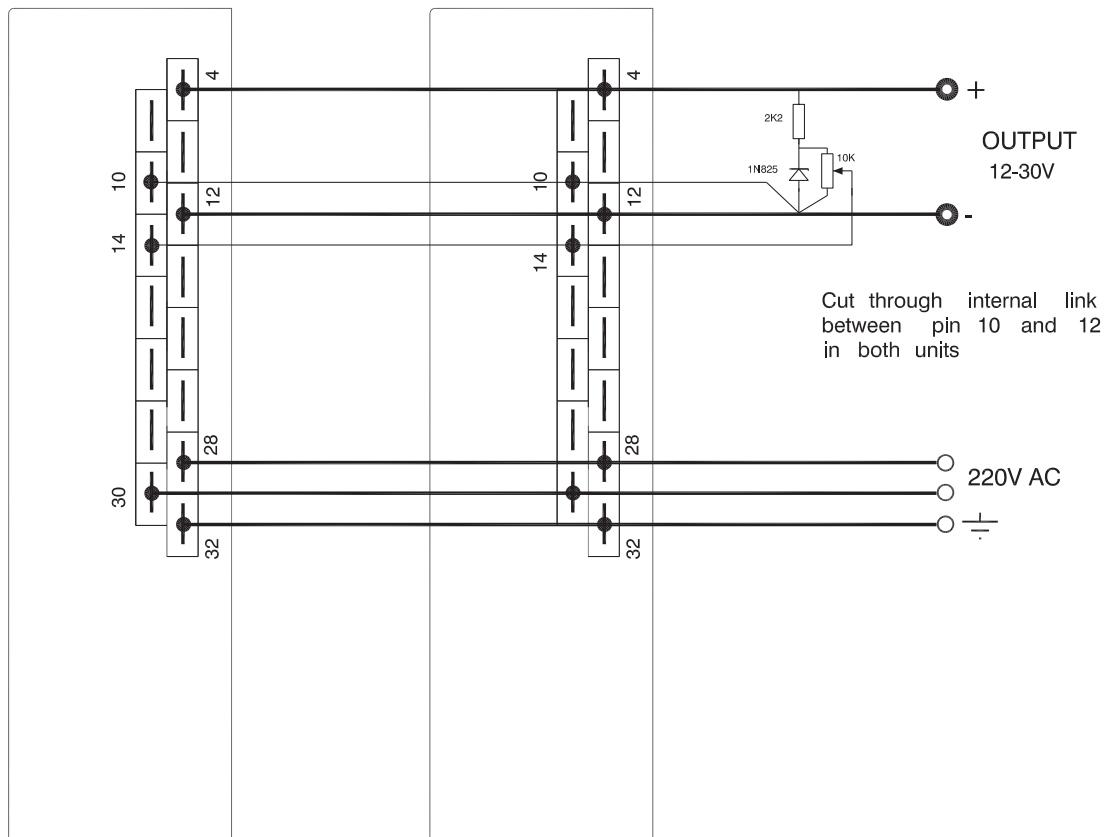

fig. 3 - 9

**10. Current limit**

The current limit is fixed but can be put at a lower level with switch SW201 on P401 (fig. 3 - 10). Normally it is on high but for parallel operation it has to be put on low. From 24 to 30 V the current limit follows a constant power characteristic and below 24 V more or less a constant current characteristic.

When the output is short circuited the input current is about 0.3 Arms.

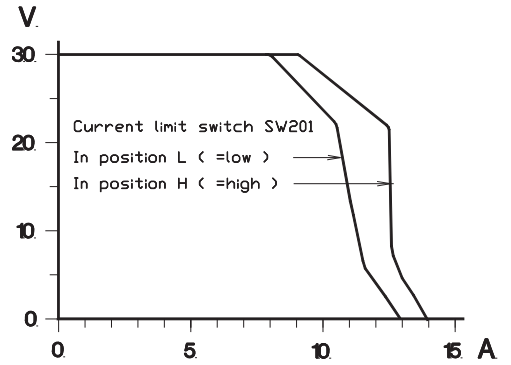

fig. 3 - 10

**11. Programming**

If switch SW101 at P402 is put on P (=program) instead of M (=manual) (fig. 3 - 11) the output voltage 12 - 30 V can be programmed by 2 - 5 V between pin 14 and pin 10 (fig. 3 - 12).

The zero of the programming voltage is connected to the minus output (pin 10) of the power supply. The range 12 - 30 V can be calibrated with the voltage adjustment potentiometer by turning it up till the output is 30 V with 5 V programming voltage.

The programming speed is 100 milliseconds for a change from 12 to 30 V at 8 A.

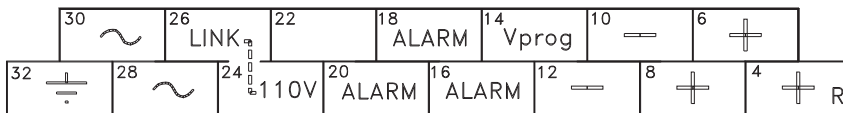

fig. 3 - 12

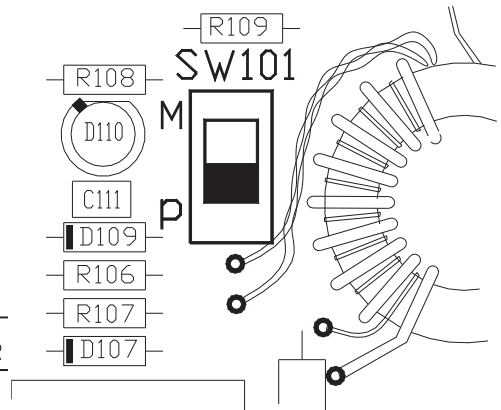

fig. 3 - 11

**12. Remote sensing**

Because remote sensing is seldom used and sometimes confuses users the S+ and S- are connected to + and - internally (fig. 3 - 13).

However if remote sensing is required, two links at the PCB (near the connector) have to be cut through.

These links are shorts between pin 6 and 8 and between 10 and 12. When they are cut pin 8 becomes the S+ and pin 10 the S- terminal (fig. 3 - 14).

The maximum sense range is 5 V per wire. However the sum of the sense and load voltage cannot be more than 30 V at 8 A.

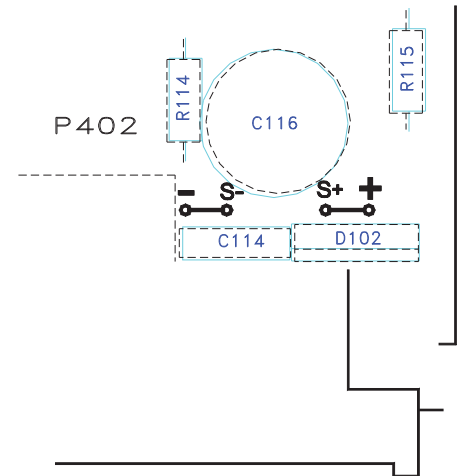

fig. 3 - 13

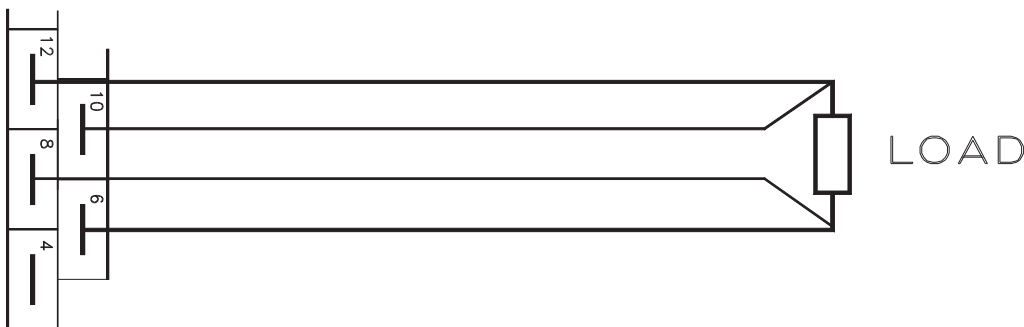

fig. 3 - 14 - Remote sensing

**13. Voltage adjustment with external potentiometer**

Remove internal link between S+ and +.  
 Remove R115 (fig. 3 - 15).  
 Connect the external potentiometer of 10 kOhm between pin 8 and pin 6.  
 Turn the internal potentiometer to zero (about 20 turns anticlockwise).  
 This method of external voltage control cannot be used with parallel operation.

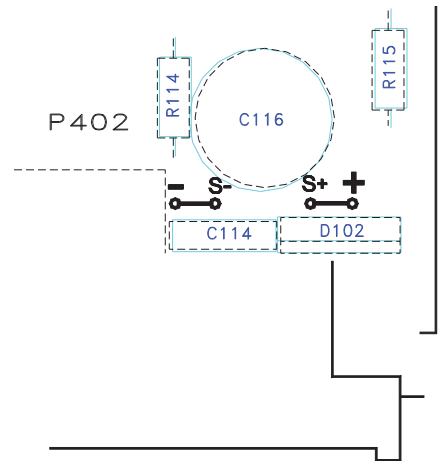

fig. 3 - 15

**14. Dividing the load in sections, each with its own fuse**

In general it is not recommended to use a fuse in the DC output of an electronic regulated power supply.  
 The electronic current limit is very fast compared to fuses and it is sharply defined so there is not enough time and not enough over current to blow a fuse.  
 This makes it difficult to divide the load in sections each with its own fuse (fig. 3 - 16).

Even for very fast fuses the time to blow is still in the order of 50 seconds at twice the nominal current ( $2 I_N$ ).  
 At  $4 I_N$  this is already much better and can be in the order of 20 milliseconds.  
 However compared with the electronic current limit this is still too long and all sections will see a dip in the 24 V.  
 The best results we found with the circuit breakers S 280 Z of ABB. They are the fastest.

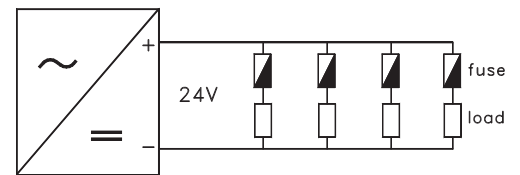

fig. 3 - 16

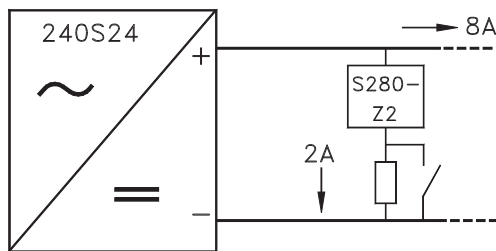

fig. 3 - 17

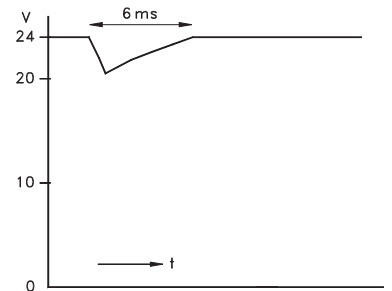

fig. 3 - 18

In the above situation (see fig. 3 - 17 and fig. 3 - 18) there is still a voltage dip during 6 ms. This can be very much improved by a large electrolytic capacitor which can supply a high current peak for a fast action of a fuse or a circuit breaker.

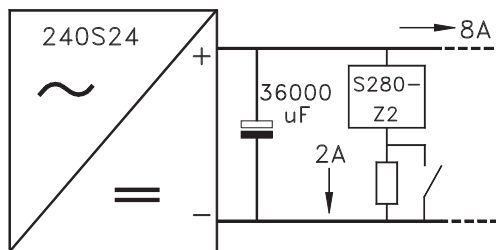

fig. 3 - 19

240S24 with 36000  $\mu$ F parallel

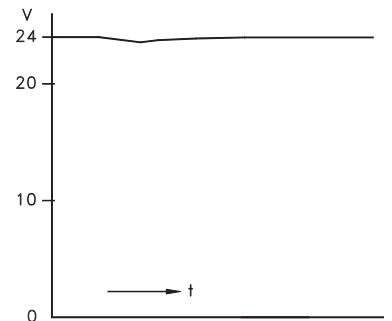

fig. 3 - 20

A disadvantage of the large electrolytic capacitor can be that the current limit is no longer fast.

The inductance of long leads (several meters) between the power supply and the load can cause very large voltage dips when a fuse is blown. This can be avoided by connecting the electrolytic capacitor close to the load (see fig. 3 - 19 and fig. 3 - 20).





P.O. Box 27  
4300 AA Zierikzee  
The Netherlands

Tel. +31 111 413656  
Fax. +31 111 416919  
www.deltapowersupplies.com

**DELTA ELEKTRONIKA B.V.**

## EC Declaration of Conformity

We

Delta Elektronika  
P.O. BOX 27  
4300 AA ZIERIKZEE  
The Netherlands

Declare under sole responsibility that the following Power Supply:

### **240 S 24**

Meets the intent of Directives 2004/108/EC for Electromagnetic Compatibility and Directives 2006/95/EC regarding Electrical Safety. (Low Voltage Directive)  
Compliance was demonstrated to the following specification as listed in the official Journal of the European Communities:

#### **EN 61000-6-3 Generic Emissions:** (residential, light industrial)

EN 55022 Radiated and conducted, Class **B**  
EN 61000-3-2 Power Harmonics  
EN 61000-3-3 Voltage fluctuation and flicker

#### **EN 61000-6-1 Generic Immunity:** (residential, light industrial)

#### **EN 61000-6-2 Generic Immunity:** (industrial environment)

EN 61000-4-2 Electrostatic Discharge  
EN 61000-4-3 Radiated electromagnetic fields  
EN 61000-4-4 Electrical Fast Transients / Bursts  
EN 61000-4-5 Surge immunity  
EN 61000-4-6 RF common mode, conducted  
EN 61000-4-11 Voltage variations and dips

#### **EN 60950 Safety of IT equipment**

#### **EN 61010 Safety of electrical equipment for measurement, control and laboratory use**

Managing director



**DELTAELEKTRONIKA B.V.**

PO Box 27  
4300 AA Zierikzee  
The Netherlands  
Tel. +31 111 413656  
Fax. +31 111 416919

Vissersdijk 4  
4301 ND Zierikzee  
The Netherlands

[www.deltapowersupplies.com](http://www.deltapowersupplies.com)

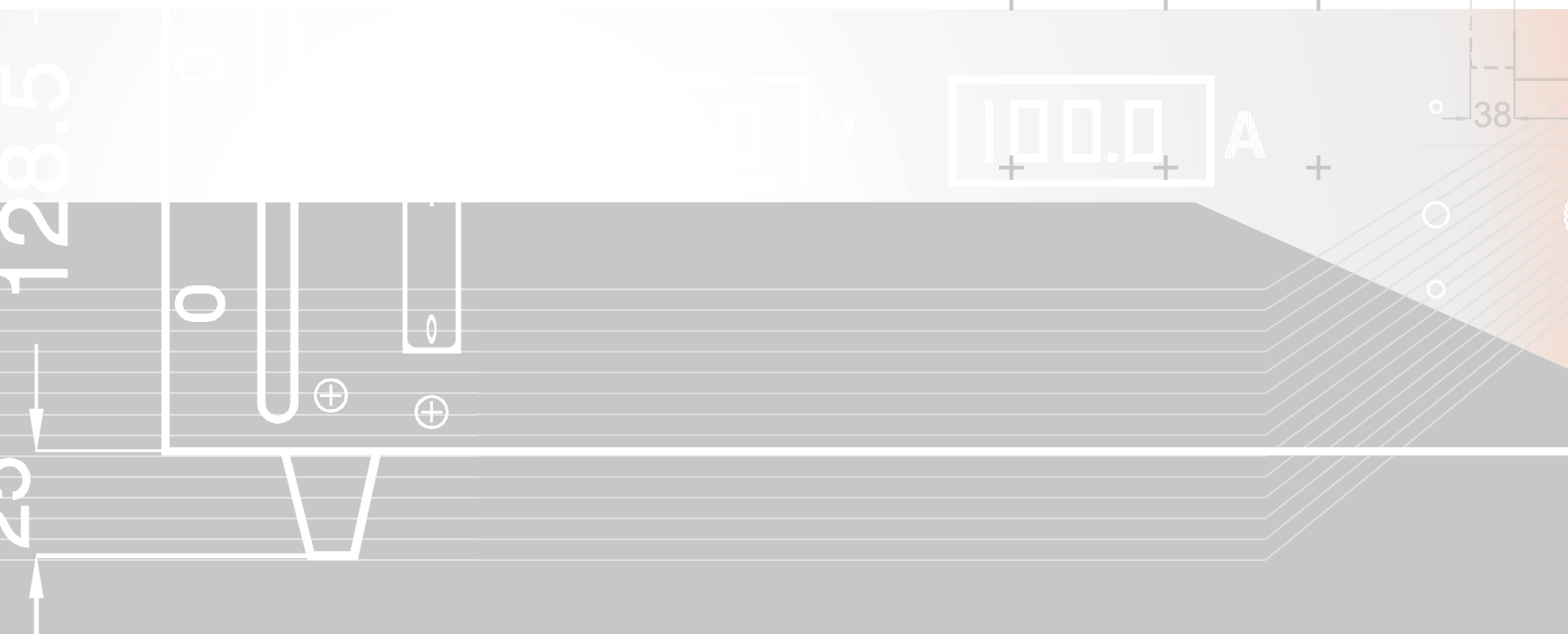

DC POWER SUPPLIES